

超高转速·低振动的 牙科涡轮手机用轴承

作为牙科手机的主要零件,ISC的轴承活跃于要求超高精度、高转速的牙科用手机主要部件领域。

特 长

- 转数可应对 450,000RPM 到 500,000RPM。
- 使用新型钢材 (ES-1) 使耐腐蚀性能达到更高水平。
- 由于使用 Torlon 材质的保持架使其具有耐高温, 高压灭菌处理性能。
- 同时可生产陶瓷滚珠轴承。

标准品

(单位: mm)

型 号	主要尺寸				
	d	D	B	D ₁	C
型号 1	3.175	6.350	2.779	-	-
型号 2	3.175	6.350	2.380	-	-
型号 3	3.175	6.350	2.779	7.518	0.787
型号 4	3.175	6.350	2.380	7.518	0.584

客制品

型 号	主要尺寸				
	d	D	B	D ₁	C
型号 A	3.175	6.350	2.779	7.518	0.450
型号 B	3.175	6.350	2.779	-	-

*对于尺寸, 材质如有特殊要求, 请咨询。



普通型



法兰型

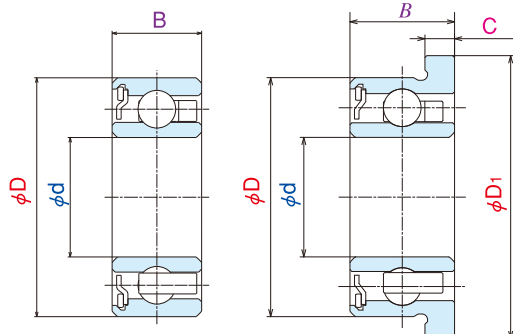

标准品

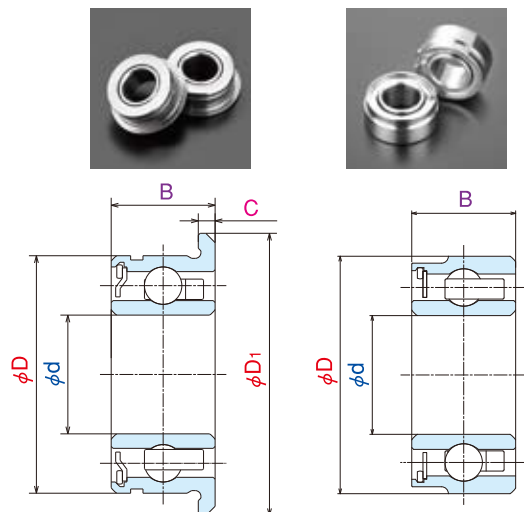

客制品

NSK MICRO PRECISION CO.,LTD.

<http://www.nskmicro.co.jp/>

本 部 邮编101-0054 日本国东京都千代田区神田锦町3-17广濑大楼6楼
电话: 0081-3-5283-7420 传真: 0081-3-5259-0882

大阪业务所 邮编540-0032 大阪市中央区天满桥京町2-13 WATAKI天满桥大楼301
电话: 0081-6-6942-0858(代表) 传真: 0081-6-6941-9113

松本业务所 邮编 399-3303 长野县下伊那郡松川町元大岛2953
电话: 0081-265-48-6022(代表) 传真: 0081-265-48-6023

Ultra High Speed, Low Vibration Dental Bearing

ISC dental bearing performs exceptionally as the critical part for dental hand piece in which super high precision and ultra high speed rotation are required.

Features

- 450,000min⁻¹ ~ up to 500,000min⁻¹
- Higher anti-corrosion has been achieved with newly developed material (ES-1)
- Polyamide-imide material cage sustains higher stability against autoclave.
- Available with ceramic balls



Standard

(Unit:mm)

Type	Boundary Dimensions				
	d	D	B	D ₁	C
Type1	3.175	6.350	2.779	-	-
Type2	3.175	6.350	2.380	-	-
Type3	3.175	6.350	2.779	7.518	0.787
Type4	3.175	6.350	2.380	7.518	0.584

Customized

	d	D	B	D ₁	C
TypeA	3.175	6.350	2.779	7.518	0.450
TypeB	3.175	6.350	2.779	-	-

*Please consult with ISC for special dimensions and materials



Straight Type



Flange Type

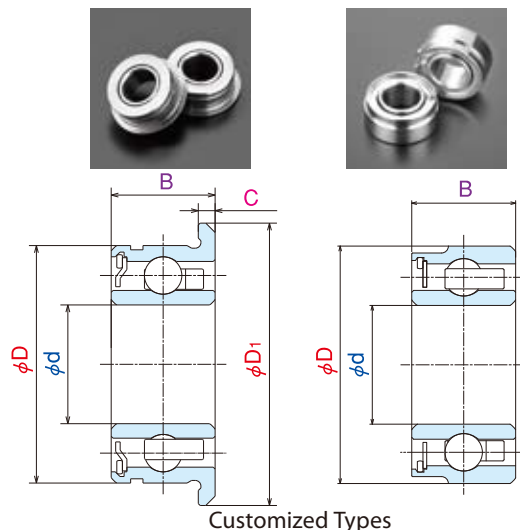
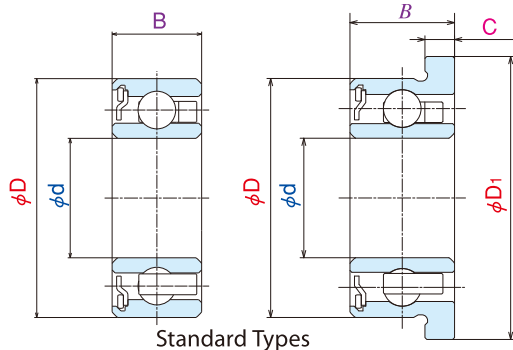

NSK Micro Precision Co., Ltd.

<http://www.nskmicro.co.jp/english> (Please visit our English site for details)

Head office/Sales Division Headquarters
 6F, Hirose Building, 3-17, Kanda-Nishikicho, Chiyoda-ku, Tokyo 101-0054 Japan
 Tel:+81-3-5283-7420 Fax:+81-3-5259-0882

Osaka Sales Office
 301 Wakita-Tenmabashi Building, 2-13, Tenmabashi-Kyomachi,
 Chuo-ku, Osaka-shi, Osaka 540-0032 Japan
 Tel:+81-6-6942-0858 Fax:+81-6-6942-9113

Matsumoto Sales Office
 2953 Moto-ojima, Matsukawa-machi, Shimonina-gun, Nagano 399-3303 Japan
 Tel:+81-265-48-6022 Fax:+81-265-48-6023

※Contents may be revised without prior notice.